

Design & Development of L-Sealer Machine

Shrinath Mahadev Patil-Mangore¹, Mangesh Mohan Mane²,
Nikhil Ramchandra Mane³, Shubham Siddhu Misal⁴, Abhinav Dipak Patil⁵

¹(Asst.Prof., Mechanical Engineering, JSPM Narhe Technical Campus, Pune, India)

^{2,3,4,5}(Student., Mechanical Engineering, JSPM Narhe Technical Campus, Pune, India)

Abstract: Packaging machines are used because a machine can wrap items more quickly, more neatly and more consistently than human being and at a fraction of the cost. One type of machine is used to cover wholly or partially individual items or collected groups of items with a flexible material, i.e. paper, metal foil, plastic or cellulose film. Machines also included in this category are those that collate and distribute items in readiness for covering, those that fill cases, those that prepare the materials and containers used in packaging and those that seal the covering.

It is a class of packaging machine. The term is generally used for those packaging machines that cover small items or collations of small items, with paper, foil or plastic film and involve folding and forming the wrapping material to provide a closed envelope, often at high speed. As regards this series of notes, for example, carton erectors, cartooning machines and case packers are packaging machines, but not wrapping machines.

Keywords: Automatic packing, wrapping, cartooning, envelope

I. Introduction

I.1 INTRODUCTION L-SEALER MACHINE

Now a days in many industries the manual operated L sealer machine is used for packaging of the component but this manual operated machine should be replaced by the automatic machine because manual L sealer machine is time consuming & requires a man near it to put & replace the component to be packaged. Manual operated L sealer machine can package a component of fixed dimensions to overcome it should be replaced by automatic operated L sealer machine. It must also be taken in account that there is a potential for misuse of original packs, especially when discarded after repackaging. Counterfeit products could be packaged into an outer packaging bearing safety features. Using center folded film, L bar sealers create bags around products with poly bagging. Heat Seal's L bar sealers are built to last with a compact footprint Add a shrink tunnel or heat gun to an L sealer to produce tightly shrink wrapped packages for shrink wrapping. Economical and great for creating single or multi-pack packages for sale, as an insert into another package or for shipping.

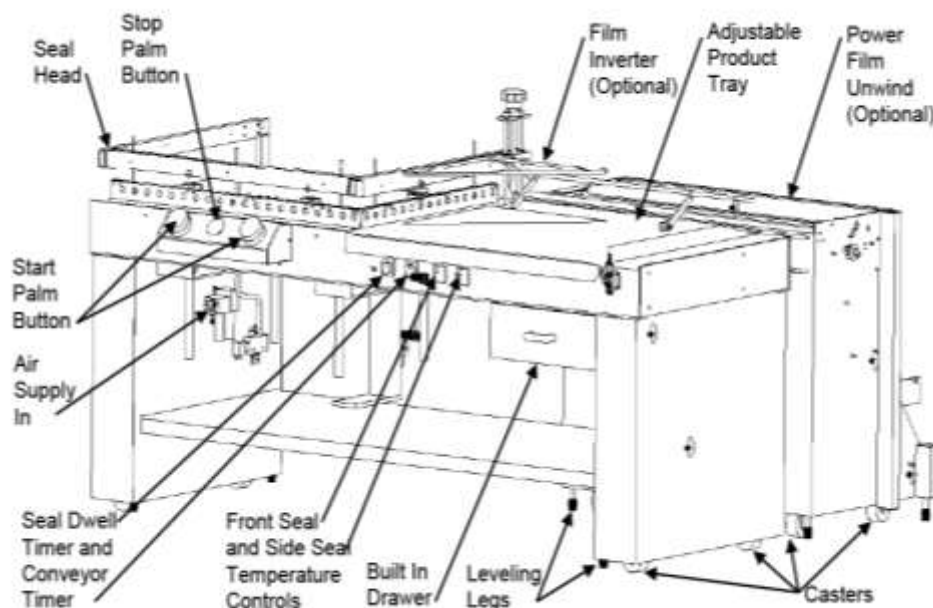

Figure 1.1 : Schematic of L-Sealer Machine

1.2 MAIN COMPONENTS OF L-SEALER MACHINE

Components of L-Sealer machine

1. Conveyor
2. Pneumatic Actuator
3. Film Installation
4. Heat Bar Sealer
5. Control Panel

1. CONVEYOR- A conveyor system is a common piece of mechanical handling equipment that moves materials from one location to another. Conveyors are especially useful in applications involving the transportation of heavy or bulky materials.

2.PNEUMATIC ACTUATOR- A Pneumatic actuator mainly consists of a piston or a diaphragm which develops the motive power. It keeps the air in the upper portion of the cylinder, allowing air pressure to force the diaphragm or piston to move the valve stem or rotate the valve control element. Valves require little pressure to operate and usually double or *triple* the input force. The larger the size of the piston, the larger the output pressure can be. Having a larger piston can also be good if air supply is low, allowing the same forces with less input.

3.FILM INSTALLATION: Select the proper width of center-fold film for the product being packaged, taking into account the width and height of the package. With the package properly positioned within the film in the sealing area, allow sufficient film to overlap the sealing bars so that a seal can easily be made without possibility of openings due to insufficient film coverage.

4. HEAT BAR SEALER: L bar sealers create bags around products with poly bagging. Heat Seal's L bar sealers are built to last with a compact footprint. Heat sealing is the process of sealing one thermoplastic to another similar thermoplastic using heat and pressure.

5.CONTRL PANEL: It is a control of various parameters. Example: Power ,Dwell ,Conveyor , Temp Control

II. Operation

Controls for the L-sealer are located along the front of the machine in two groups:

OPERATION PANEL — The three palm buttons (two start buttons with one stop button in between) are grouped together in front of the seal area in the Operation Panel.

CONTROL PANEL — The power on/off switch and controls for dwell and conveyor timer and sealer temperature controls are grouped together in the Control Panel under the product tray.

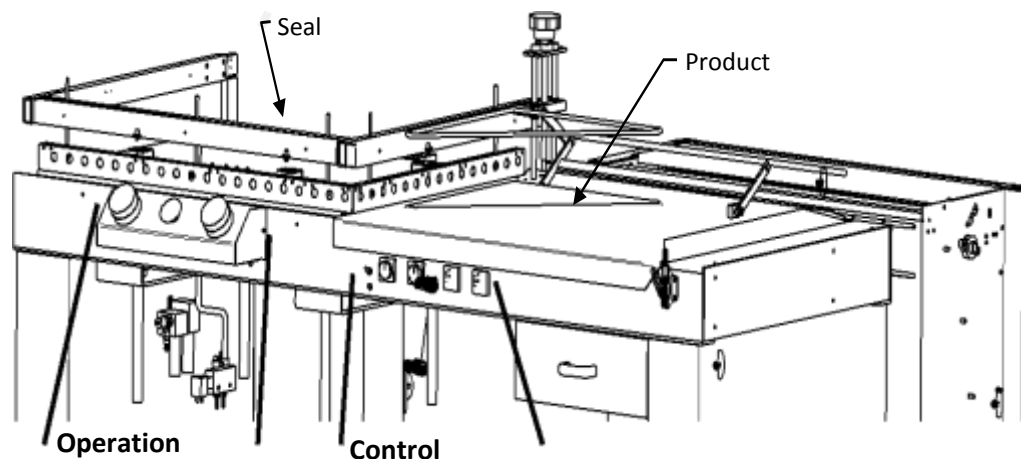

2.1 SEQUENCE OF OPERATION :

1. Place the product on the product tray. The product tray separates the film, allowing you to place the product between the upper and lower layers of film.
2. Move the product into the seal head area, pushing it to the left.
3. Move hands out of the seal head area and use both hands to press both Start palm buttons. Hold the Start palm buttons down as the seal is being made. The air cylinders hold the seal head down for the amount of time required to make the seal (dwell time). The seal head will release. The dwell time is

Operation adjustable from one (1) to five (5) seconds and is indicated on the Dwell timer indicator, which is located closest to the Power switch under the product tray.

4. Once the seal is formed completely and the seal head automatically releases. The sealed product is removed by the takeaway conveyor, and the next Item can be moved into position for sealing. The takeaway conveyor runs for the specified amount of time required to move the sealed product onward out of the sealing area. The amount of time the conveyor runs is adjustable from one to five seconds and is indicated on the Conveyor timer indicator, located next to the dwell timer indicator under the product tray. Prepare the next item to be sealed, placing it on the product tray between upper and lower layers of film as the takeaway conveyor moves the sealed product away.

2.2 HEAT SEALING PROCESS

Heat sealing is the process of sealing one thermoplastic to another similar thermoplastic using heat and pressure. The direct contact method of heat sealing utilizes a constantly heated die or sealing bar to apply heat to a specific contact area or path to seal or weld the thermoplastics together. Heat sealing is used for many applications, including heat seal connectors, thermally activated adhesives, film media, plastic ports or foil sealing.

2.3 COMMON APPLICATIONS FOR THE HEAT SEALING PROCESS:

Heat seal connectors are used to join LCDs to PCBs in many consumer electronics, as well as in medical and telecommunication devices.

Heat sealing of products with thermal adhesives is used to hold clear display screens onto consumer electronic products and for other sealed thermo-plastic assemblies or devices where heat staking or ultrasonic welding are not an option due to part design requirements or other assembly considerations.

Heat sealing also is used in the manufacturing of blood test film and filter media for the blood, virus and many other test strip devices used in the medical field today. Laminate foils and films often are heat sealed over the top of thermoplastic medical trays, Microtiter (microwell) plates, bottles and containers to seal and/or prevent contamination for medical test devices, sample collection trays and containers used for food products.

Medical and fluid bags used in the medical, bioengineering and food industries.

III. Conveyor

3.1 CONCEPT GENERATION AND EVALUATION

The primary aim of concept generation and evaluation is to ensure that the product can perform all of the major functions. Hand drawn sketches are developed by considering the entire requirement that performed during the stage of understanding the opportunity. Number of possible concepts is generated for length adjusting, height adjusting, powered & gravity type requirements and these concepts are evaluated using Pugh's evaluation method. Pantograph Mechanism is selected to adjust the length adjusting option, which can be used as powered and gravity conveyors. Bolt-Nut mechanism is used to adjust the height. During this stage a FAST-Diagram is developed that describes the decomposition of the product functionally and physically. After that the concept for whole machinery is developed incorporating these mechanisms and overall feature bench marked with competing products.

3.2 EMBODIMENT DESIGN

Embodiment design of this work includes the quality aspects, reliability, geometry developing, performing engineering calculation etc. And the whole work is classified as Qualitative Analysis and Quantitative analysis

3.2.1 QUALITATIVE ANALYSIS

In order to ensure an overall quality design, a complete qualitative engineering analysis of multipurpose conveyor unit is carried out. Also considering the Design for Manufacturing and Assembly (DFMA), Design for Failure Mode and Effects Analysis (DFMEA), as well as Design for Environment (DFE), are followed.

3.2.2 DESIGN FOR MANUFACTURING AND ASSEMBLY (DFMA)

Throughout the process of finalizing the design, we considered the factors for easy manufacturing and assembly by minimizing part and making necessary arrangements for easier maintenance in future. Most of the parts are taken as Standard in order to maintain the overall quality. Design for joining (DFJ) is adequately considered so as to make the assembly procedure easy and the maintenance simple. Riveting of parts is eliminated since maintenance work if required will be difficult and also costly. Also Joining of parts by welding is also eliminated for easier replacement of parts at the time of service.

3.2.3 DESIGN FOR ENVIRONMENT (DFE)

During the design process we have considered the environmental impact of the product throughout its lifecycle through multiple designs for environment (DFE) guidelines. The guideline involves physical optimization, easy maintenance and repair by allowing easy access to all components of the mechanism such as length adjusting as well as height adjusting, material optimization.

3.2.2 DESIGN FAILURE MODE EFFECT ANALYSIS (DFMEA)

DFMEA is a structured approach that ensures potential failure modes and their associated causes have been considered and addressed in product design stage. This procedure is carried out from design conceptualization stage onwards. Each Concept is analyzed by what can go wrong? Where will the Variation come from? How can we prevent or Control? Each Concept is anticipated for cause that what can go wrong? Severity may reflect options like “not feasible” when considering DFM & DFE. The occurrence can be considered based on literature reviews, customer’s opinion, and experience and finally recommending corrective action. If the cause of problem is not anticipated it should be done at the time of PFMEA. DFMEA is carried for this work using the aid of the following data Customer Requirements, Competitive analysis, House of quality, Product design specification, Generated Concept, Literature Reviews. The minor failure means failure due to yielding initial stage corrosion formation, but this failure never affects the overall failure of the system. While the Major failure will affect the full system functioning

| Sub- Part | Part & Function | Failure Mode | Failure Effect | S | Failure Cause | O | Design Control | D | R P N | Recommendation |
|-----------|-----------------|--------------|----------------|---|------------------------------------------|---|--------------------------------------------|---|-------|---------------------------------|
| ENCLOSURE | COVERING | Corrosion | MINOR | 5 | Exposing to direct atmosphere | 3 | Avoid exposing | 2 | 3 | powder coating / heat treatment |
| | | | MAJOR | 7 | | 1 | | 2 | 1 | |
| | | Yield | MINOR | 5 | Overloading ,improper loading, alignment | 1 | Load the part which no yielding will occur | 1 | 5 | Increase the gauge of sheet |
| | | | MAJOR | 8 | | 1 | | 1 | 8 | |

For finding out width of belt required for conveyor following equation is used ,

$$M= \rho C(0.9B-0.05)^2 v* 3600$$

From above equation taking velocity =1m/s , density =700kg/m^3 and mass as 50*10^3 kg/hr ,

We found out width as 600 mm

By taking resistance at different points along belt conveyor tensions at tight and slack side is calculated as

$$F_{tight} =3.6068F_{slack}$$

$$3.6068F_{slack} =1.192F$$

$$F_{slack} =2709.48N$$

$$F_{tight} =9772.57N$$

The maximum tension in belt conveyor is ,

$$F_{tmax} = F_t = F_c = F_t + m_b v^2$$

$$= 9772.57 + 9 * (1.25)^2$$

$$F_{tmax} = 9786.6$$

IV. Pneumatic Actuator

Pneumatic cylinder, Rotary actuators and Air motors provide the force and movement of most pneumatic control systems, to hold, move, and form and process material. To operate and control these actuators, other pneumatic components are required i.e. air service units to prepare the compressed air and valves to control the pressure, flow and direction of movement of the actuators.

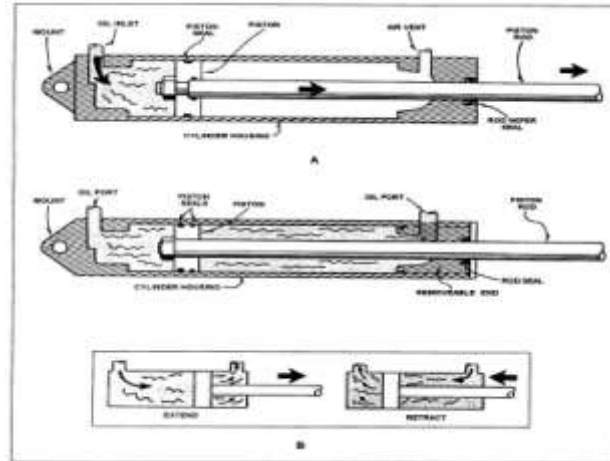

In practice, the effective piston force is significant in calculating the effective piston force, the frictional resistance must be taken into account. Under normal operating conditions (pressure range 400-800kpa 4-8bar), the frictional forces may be assumed to be between 3-20% of the calculated force. Single acting cylinders.

Design of selection of actuator cylinder

P=5bar

F_e =50n (during extension)

F_r=100n (durng retraction)

Selection of cylinder

1) during extension

$$D_e = \sqrt{\frac{4F_e}{\pi p}}$$

$$= \sqrt{\frac{4 \times 50}{\pi \times (5 \times 10^5)}}$$

$$= 11.2837 \times 10^{-3} \text{m}$$

d_e =11.28m

2) during retraction

$$D_r = \sqrt{\frac{4F_r}{\pi P}}$$

$$= \sqrt{\frac{4 \times 100}{\pi \times (5 \times 10^5)}} = 15.9576 \times 10^{-3} \text{m}, D_r = 15.95 \text{mm}$$

V. Conclusion

In this research work include all the design development procedures are carried out as per industrial procedure. To meet the demand of a length adjusting, height adjusting powered type conveyor system for packaging machine we researched the market, spoke with the customers and met with key individuals in the field in order to fully define the scope of our task. Also type of heater mechanism for sealing and packing and automaton using pneumatic actuators is considered. Various detailed analysis is done for selection of these components. From this research, customer requirements were defined which were turned into engineering specifications and correlated using the aid of a QFD diagram. From the QFD the most important design characteristics are length adjusting, height adjusting, material Selection, quality, cost are considered at the time of design calculation. To move forward with the design a project plan was developed that outlined key factor comprised of completion of product specification, concept generation, embodiment design and detailed design including qualitative, quantitative analysis, detailed design. Finally a comparative study based upon several cases is developed.

Reference

- [1]. *Lihua ZHAO*, Typical failure analysis and processing of belt conveyor, *Procedia Engineering* 26 (2011) 942 – 946, First International Symposium on Mine Safety Science and Engineering.
- [2]. *Gabriel Fedorkoa**, *Vladimir Ivanob*, Analysis of Force Ratios in Conveyor Belt of Classic Belt Conveyor, *Procedia Engineering* 48 (2012) 123 – 128 MMaMS 2012.
- [3]. *Helmi Rashida**, *Mohd Khairul Anuar Mohd Ariffinb*, *Mohd Hafiz Mohd Noha*, *Abdul Halim Abdullaha*, *Ahmad Hussein Abdul Hamida*, *Mohammad Azzeim Mat Jusoha*, *Akbar Othman*, Design Review of Scissors Lifts Structure for Commercial Aircraft Ground Support Equipment using Finite Element Analysis, *International Symposium on Robotics and Intelligent Sensors 2012 (IRIS 2012)*
- [4]. *Beater, P.*, 2007. *Pneumatic Drives: System Design, Modelling and Control*. Springer, Berlin.
- [5]. *Belforte, G.*, *Mattiazzo, G.*, *Mauro, S.*, *Tokashiki, L.R.*, 2003. Measurement of friction force in pneumatic cylinders. *Tribotest* 10, 33e48.
- [6]. *Alberto Regattieria**, *Francesco Pianaa*, *Mauro Gamberia*, *Francesco Gabriele Galiziab*, *Andrea Casto*:- “Reliability assessment of a packaging automatic machine by accelerated life testing approach”
- [7]. *A . Mhalla* , *S. Collart Dutilleul* and *M. Benrejeb* “Monitoring of Packaging Machine Using Synchronized Fuzzy Petri Nets.”
- [8]. *Gresher JM*. *Carded packaging*. In: *Bakker M*, Wiley John Wiley & Sons “Packaging Equipment”
- [9]. *Chourasia, M.K.*, *Goswami, T.K.*:- “Materials handling, storage and distribution.”